



Peelers Vegetable Peeler, 5kg with abrasive plate

ITEM # _____

MODEL # _____

NAME # _____

SIS # _____

AIA # _____

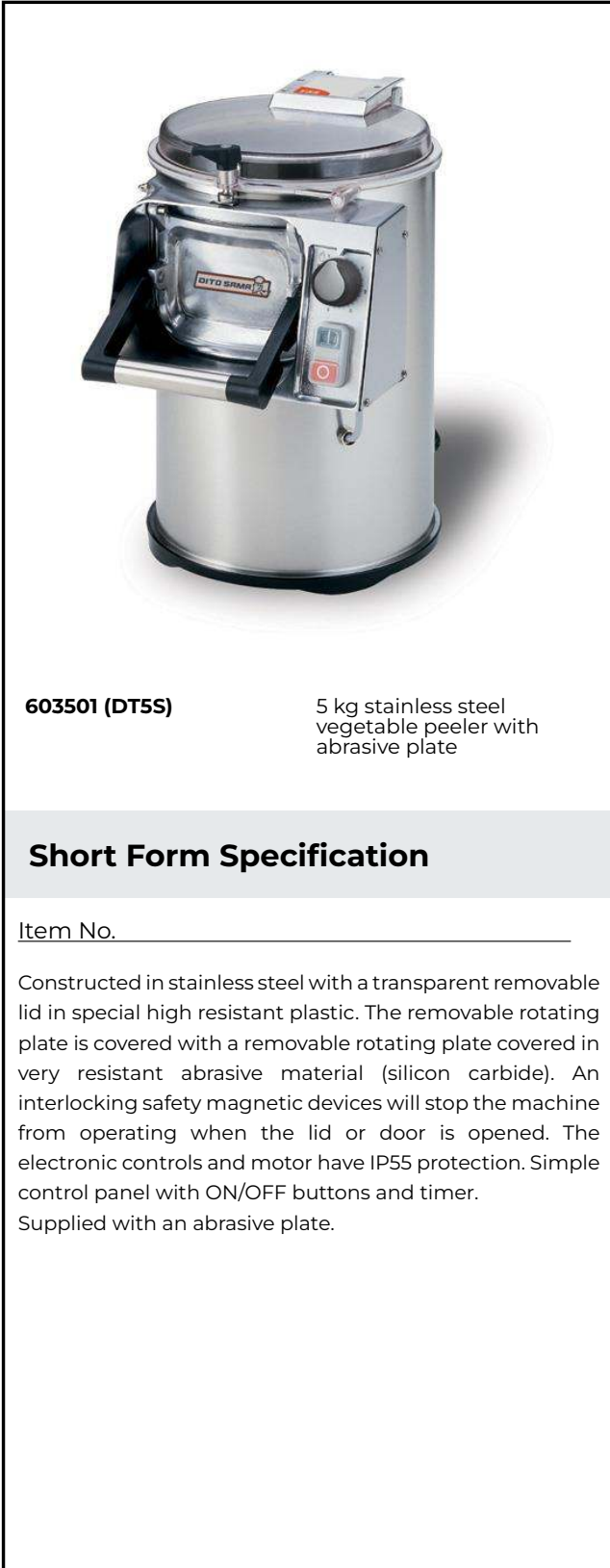

603501 (DT5S)

5 kg stainless steel vegetable peeler with abrasive plate

Short Form Specification

Item No. _____

Constructed in stainless steel with a transparent removable lid in special high resistant plastic. The removable rotating plate is covered with a removable rotating plate covered in very resistant abrasive material (silicon carbide). An interlocking safety magnetic devices will stop the machine from operating when the lid or door is opened. The electronic controls and motor have IP55 protection. Simple control panel with ON/OFF buttons and timer. Supplied with an abrasive plate.

Main Features

- Supplied with an abrasive plate as standard.
- Removable rotating plate covered in very resistant abrasive material (silicon carbide).
- Products downloading made easy thanks to the specific chute, activating manually the disc rotation to channel the product out of the peeling chamber.
- Magnetic detectors will stop the machine from operating when the lid and/or door are opened.
- Red OFF, green ON buttons and timer knob.
- Productivity suitable for 30-100 meals per service.

Construction

- Stainless steel construction with transparent lid in damage resistant plastic.
- IP55 waterproof control buttons.
- Transparent BPA free cover incorporates a magnetic safety system which stops the machine if lid is not properly closed.

Included Accessories

- 1 of Abrasive plate for 5 kg vegetable peeler (T5S) PNC 653182

Optional Accessories

- Washing plate for 5 kg vegetable peeler PNC 653057
- Abrasive plate for 5 kg vegetable peeler (T5S) PNC 653182
- Knife plate for 5 kg vegetable peeler (T5S) PNC 653183
- Filter table with sliding shelf, pre-assembled PNC 653783
- Filter table with sliding shelf PNC 653784

APPROVAL: _____

Front

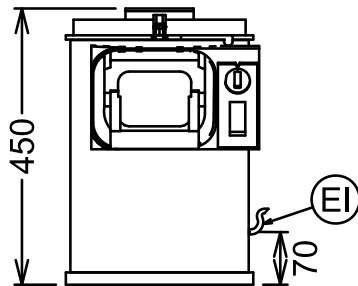

Electric

Supply voltage:

603501 (DT5S)

220-240 V/1N ph/50/60 Hz

Electrical power max.:

0.12 kW

Total Watts:

0.12 kW

Capacity:

Performance (up to):

80 kg/hour

Capacity:

5 kg

Key Information:

External dimensions,

Width:

314 mm

External dimensions,

Depth:

485 mm

External dimensions,

Height:

450 mm

Shipping weight:

21 kg

Side

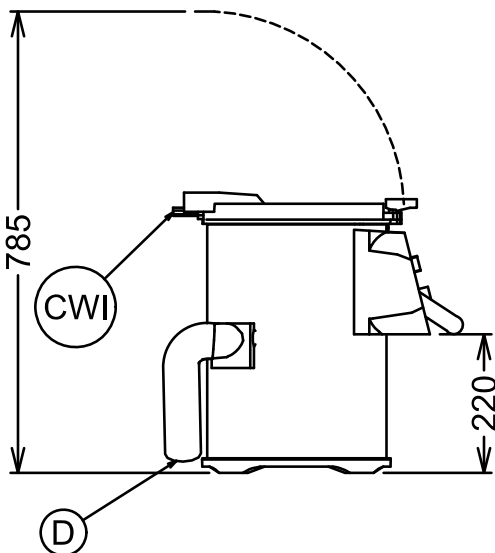

CWI = Cold Water inlet 1
(cleaning)

D = Drain

EI = Electrical inlet
(power)

Top

